

NAIS

**MOST ADVANCED
POLARIZED RELAY**

TQ-RELAYS

**UL File No.: E43149
CSA File No.: LR26550**

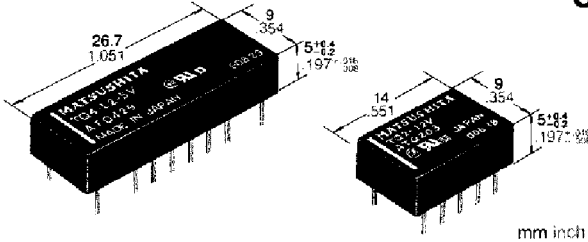

- Ultra-small size
- High sensitivity:
 - 2 Form C; 140mW power consumption (single side stable type)
 - 4 Form C; 280mW power consumption (single side stable type)
- Surge voltage withstand: 1500V FCC Part 68
- Sealed construction allows automatic washing.
- Self-clinching terminal also available.
- M.B.B. contact types available.
- TQ2SA surface mount type available

SPECIFICATIONS

Contact

Arrangement	2 Form C, 4 Form C	
Initial contact resistance, max. (By voltage drop 6V DC 1A)	50mΩ	
Contact material	Gold-clad silver	
Rating	Max. switching power	30W, 62.5VA (resistive load)
	Max. switching voltage	110V DC, 125V AC
	Max. switching current	1A
	Min. switching capability	10μA, 10mV DC
UL/CSA rating	1A 30V DC 0.3A 110V DC 0.5A 125V AC	
Expected life (min. operations)	Mechanical (at 180cpm)	10 ⁶
	Electrical (at 20cpm)	2 × 10 ⁵
	1A 30V DC resistive 0.5A 125V AC resistive	10 ⁶

Characteristics (at 20°C 68°F)

Max. operating speed	20cpm	
Operate time (at nominal voltage)	Approx. 2msec.	
Release time (at nominal voltage)	Approx. 1msec.	
Set time (latching) (at nominal voltage)	Approx. 2msec.	
Reset time (latching) (at nominal voltage)	Approx. 2msec.	
Initial breakdown voltage	Between open contacts	750Vrms for 1 min.
	Between contact sets	1,000Vrms for 1 min.
	Between contact and coil	1,000Vrms for 1 min.
FCC surge voltage between open contacts	1,500V	
Initial insulation resistance	Min. 1,000MΩ (at 500V DC)	
Temperature rise (at nominal voltage)	Max. 50 deg.	
Ambient temperature	-40°C to +70°C -40°F to +158°F	
Shock resistance	Functional	50G
	Destructive	100G
Vibration resistance	Functional	18G, 10 to 55Hz at double amplitude of 3mm
	Destructive	30G, 10 to 55Hz at double amplitude of 5mm
Unit weight	2 Form C: Approx. 1.5g 0.53oz. 4 Form C: Approx. 3g 0.106oz.	

ORDERING INFORMATION

Ex. TQ 2 H - L2 - 2M - 3V

Contact arrangement	Terminal shape	Operating function	MBB function	Coil voltage (DC)
2: 2 Form C	Nil: Standard PC board terminal H: Self-clinching terminal	Nil: Single side stable L: 1 coil latching L2: 2 coil latching	Nil: Form C type 2M:2MBB (2 Form D)	3, 4.5, 5, 6, 9, 12, 24V

Note: AgPd stationary contact types available for high resistance against contact sticking.
When ordering, please add suffix "-3" like TQ2-12V-3.

TYPES AND COIL DATA (at 20°C 68°F)

1. 2 Form C type

Operating function	Part No.	Nominal voltage, V DC	Pick-up/set voltage, V DC (max.)	Drop-out/reset voltage, V DC (min.)	Nominal operating current, mA (±10%)	Coil resistance, Ω (±10%)	Nominal operating power, mW	Max. allowable voltage, V DC
Single side stable	TQ2-3V	3	2.25	0.3	46.7	64.3	140	4.5
	TQ2-4.5V	4.5	3.38	0.45	31.1	144.6	140	6.7
	TQ2-5V	5	3.75	0.5	28.1	178	140	7.5
	TQ2-6V	6	4.5	0.6	23.3	257	140	9
	TQ2-9V	9	6.75	0.9	15.5	579	140	13.5
	TQ2-12V	12	9	1.2	11.7	1,028	140	18
	TQ2-24V	24	18	2.4	9.3	2,880	200	36
1 coil latching	TQ2-L-3V	3	2.25	2.25	33.3	90	100	4.5
	TQ2-L-4.5V	4.5	3.38	3.38	22.2	202.5	100	6.7
	TQ2-L-5V	5	3.75	3.75	20	250	100	7.5
	TQ2-L-6V	6	4.5	4.5	16.7	360	100	9
	TQ2-L-9V	9	6.75	6.75	11.1	810	100	13.5
	TQ2-L-12V	12	9	9	8.3	1,440	100	18
	TQ2-L-24V	24	18	18	6.3	3,840	150	36
2 coil latching	TQ2-L2-3V	3	2.25	2.25	66.7	45	200	4.5
	TQ2-L2-4.5V	4.5	3.38	3.38	44.4	101.2	200	6.7
	TQ2-L2-5V	5	3.75	3.75	40	125	200	7.5
	TQ2-L2-6V	6	4.5	4.5	33.3	160	200	9
	TQ2-L2-9V	9	6.75	6.75	22.2	405	200	13.5
	TQ2-L2-12V	12	9	9	16.7	720	200	18
	TQ2-L2-24V	24	18	18	12.5	1,920	300	36

2. 4 Form C type

Operating function	Part No.	Nominal voltage, V DC	Pick-up/set voltage, V DC (max.)	Drop-out/reset voltage, V DC (min.)	Nominal operating current, mA ($\pm 10\%$)	Coil resistance, Ω ($\pm 10\%$)	Nominal operating power, mW	Max. allowable voltage, V DC
Single side stable	TQ4-3V	3	2.25	0.3	93.8	32	280	4.5
	TQ4-4.5V	4.5	3.38	0.45	62.2	72.3	280	6.7
	TQ4-5V	5	3.75	0.5	56.2	89	280	7.5
	TQ4-6V	6	4.5	0.6	46.5	129	280	9
	TQ4-9V	9	6.75	0.9	31.1	289	280	13.5
	TQ4-12V	12	9	1.2	23.3	514	280	18
1 coil latching	TQ4-L-3V	3	2.25	2.25	66.6	45	200	4.5
	TQ4-L-4.5V	4.5	3.38	3.38	44.4	101.2	200	6.7
	TQ4-L-5V	5	3.75	3.75	40	125	200	7.5
	TQ4-L-6V	6	4.5	4.5	33.3	180	200	9
	TQ4-L-9V	9	6.75	6.75	22.2	405	200	13.5
	TQ4-L-12V	12	9	9	16.7	720	200	18
2 coil latching	TQ4-L2-3V	3	2.25	2.25	133	22.5	400	4.5
	TQ4-L2-4.5V	4.5	3.38	3.38	88.9	50.6	400	6.7
	TQ4-L2-5V	5	3.75	3.75	80	62.5	400	7.5
	TQ4-L2-6V	6	4.5	4.5	66.6	90	400	9
	TQ4-L2-9V	9	6.75	6.75	44.4	202.5	400	13.5
	TQ4-L2-12V	12	9	9	33.3	360	400	18
	TQ4-L2-24V	24	18	18	16.7	1,440	400	36

Notes: 1. Please add "H" for self-clinching terminal types as TQ4H-L-3V, TQ2H-L-24V.
 2. Specified value of the pick-up, drop-out, set and reset voltage is with the condition of square wave coil pulse.
 3. Standard packing: Tube:50pcs Case:1,000pcs

DIMENSIONS

1) 2 Form C

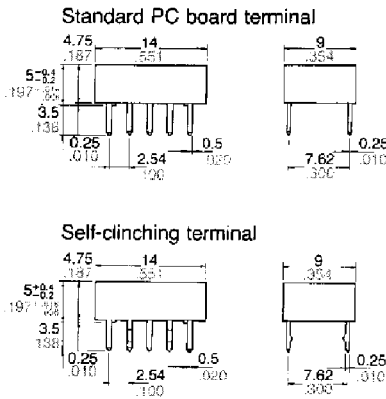

PC board pattern (Copper-side view)

mm inch

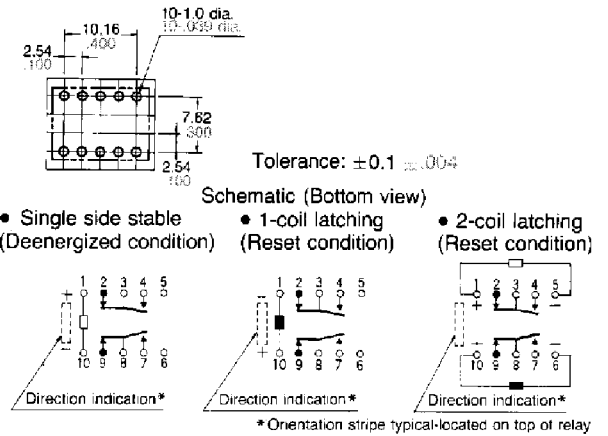

2) 2 Form C

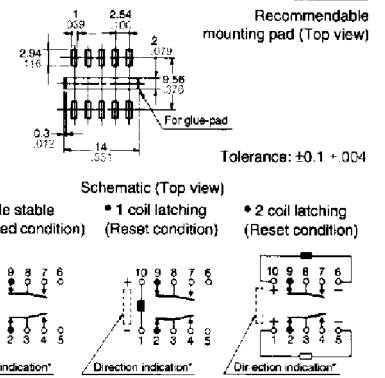
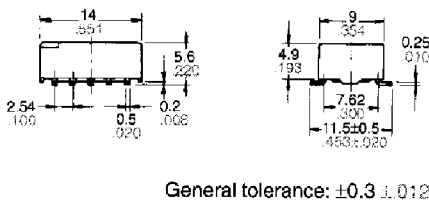

3) 4 Form C

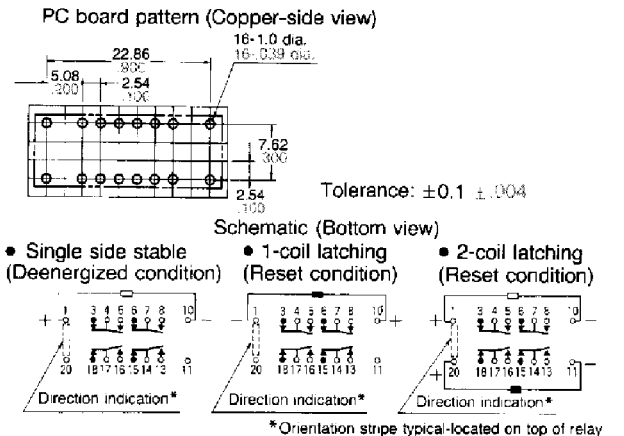
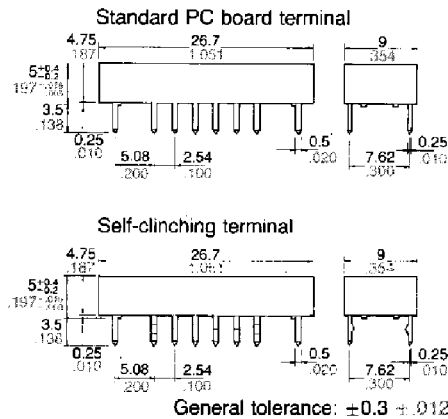
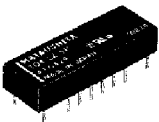

TQ

DATA

1. Maximum switching power

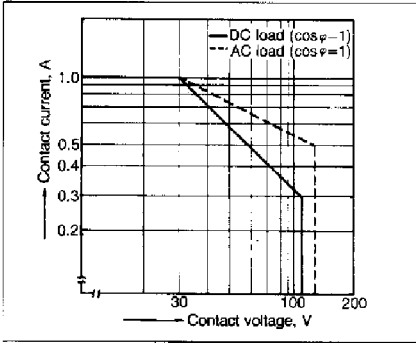

2. Life curve

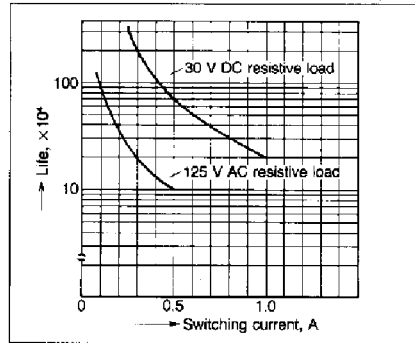

3. Mechanical life

Tested sample: TQ2-12V, 10 pcs.

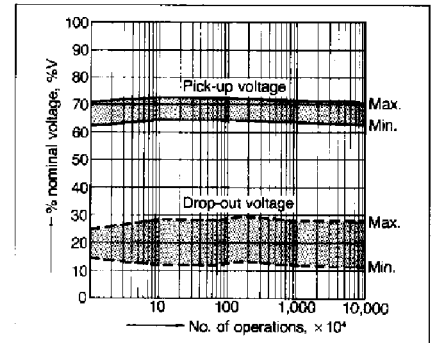

4.-(1) Electrical life (DC load)

Tested sample: TQ2-12V, 6 pcs.

Condition: 1 A 30 V DC resistive load, 20 cpm

Change of pick-up and drop-out voltage

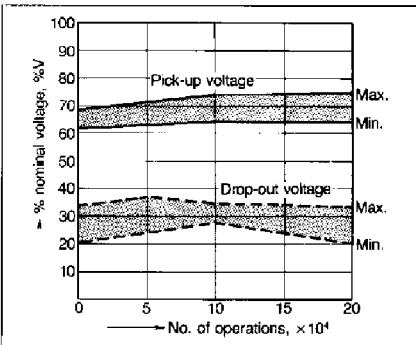

Change of contact resistance

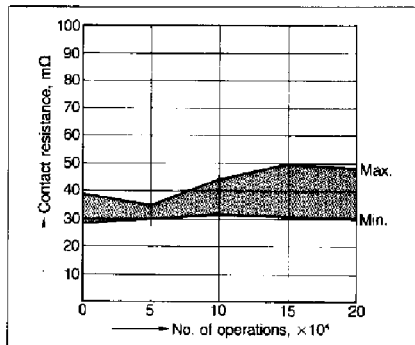

4.-(2) Electrical life (AC load)

Tested sample: TQ2-12V, 6 pcs.

Condition: 0.5 A 125 V AC resistive load, 20 cpm

Change of pick-up and drop-out voltage

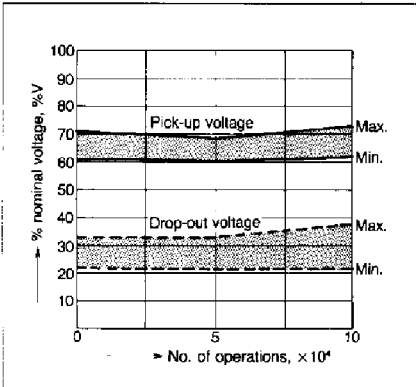

Change of contact resistance

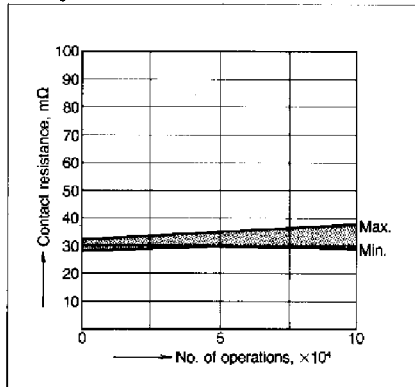

5.-(1) Coil temperature rise (2C)

Tested sample: TQ2-12V

Measured portion: inside the coil
Ambient temperature: 30°C 86°F

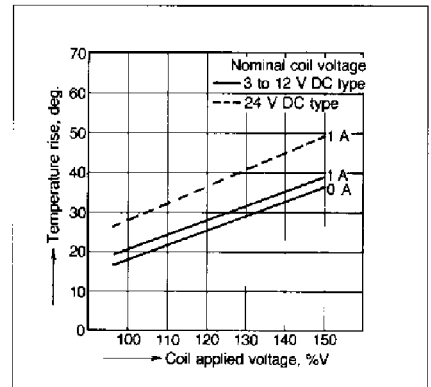

5.-(2) Coil temperature rise (4c)

Tested sample: TQ4-12V

Measured portion: inside the coil
Ambient temperature: 30°C 86°F

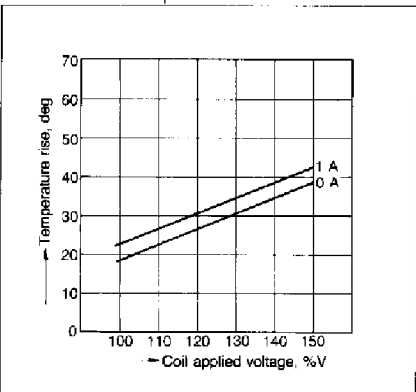

6.-(1) Operate/release time characteristics

Tested sample: TQ2-12V, 10 pcs.

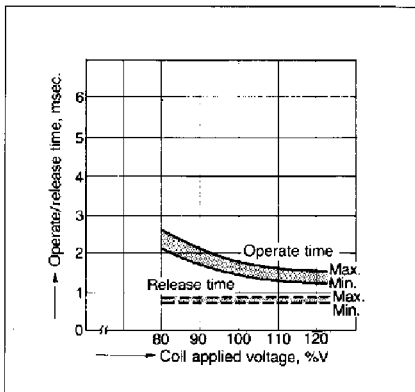

6.-(2) Operate/release time characteristics

Tested sample: TQ4-12V, 10 pcs.

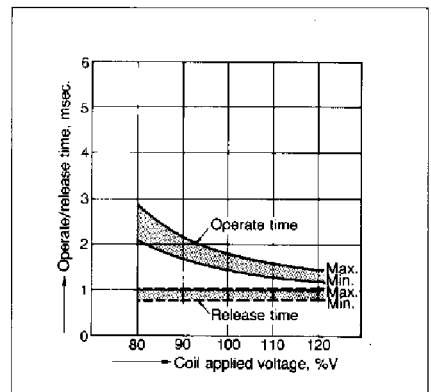

7. Distribution of pick-up and drop-out voltages
Tested sample: TQ2-12V, 50 pcs.

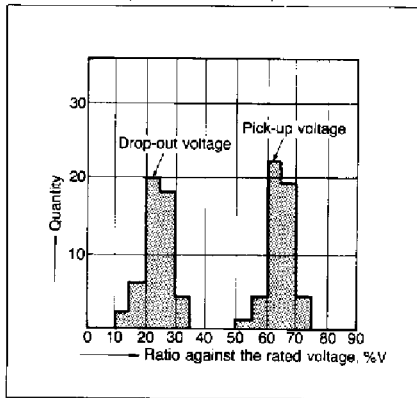

8. Distribution of set and reset voltage
Tested Sample: TQ2-L2-12V, 35 pcs.

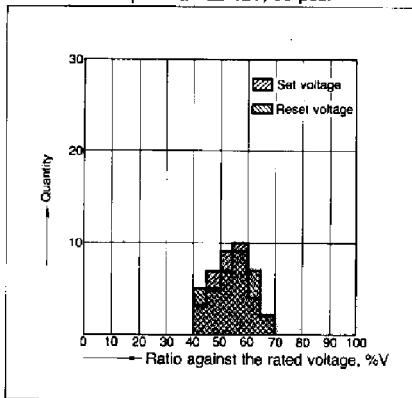

9. Ambient temperature characteristics
Tested sample: TQ2-12V, 5 pcs.

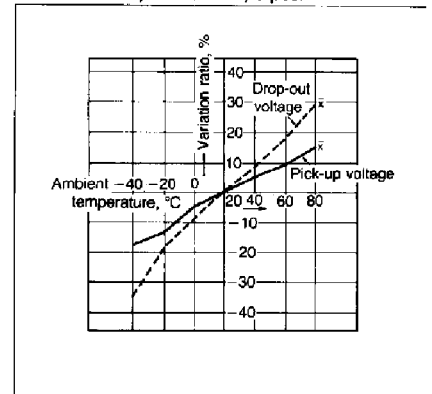

10. Distribution of contact resistance
Tested sample: TQ2-12V, 30 pcs. (30x4 contacts)

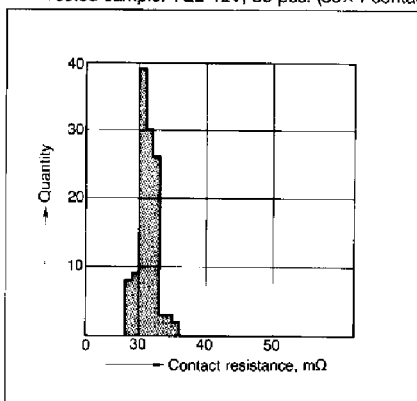

11.-(1) High-frequency characteristics
Isolation loss characteristics

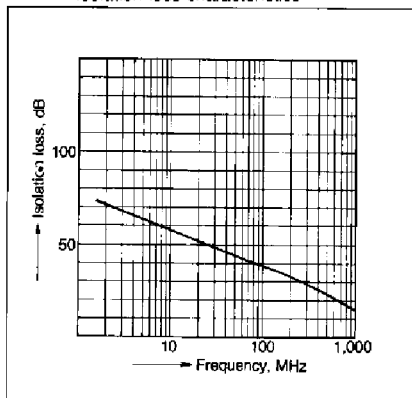

11.-(2) High-frequency characteristics
Insertion loss characteristics

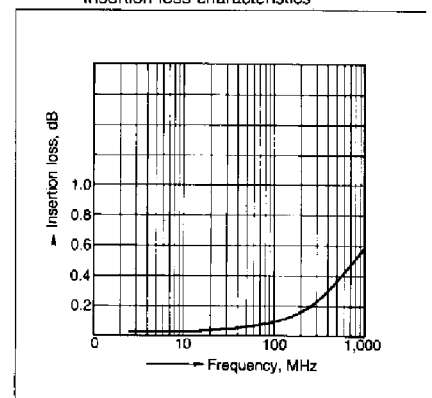

12.-(1) Malfunctional shock (single side stable)
Tested sample: TQ2-12V, 6 pcs.

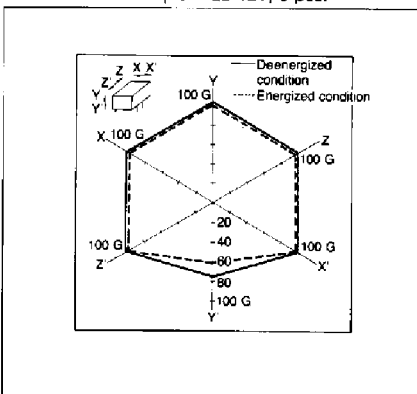

12.-(2) Malfunctional shock (latching)
Tested sample: TQ2-L-12V, 6 pcs.

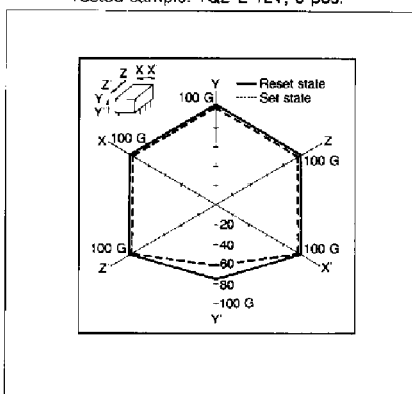

13.-(1) Influence of adjacent mounting

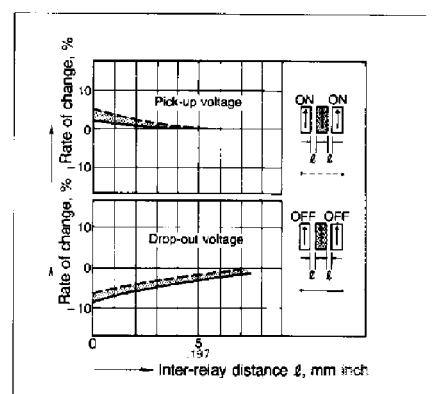

13.-(2) Influence of adjacent mounting

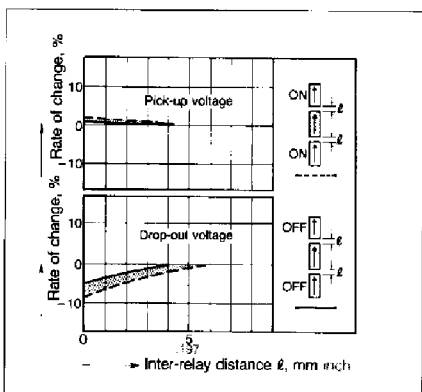

13.-(3) Influence of adjacent mounting

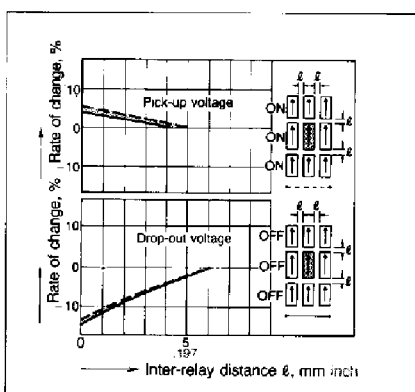

14-(1) Contact reliability
(1 mA 5 V DC resistive load)
Tested sample: TQ2-12V
Condition: Detection level 10 Ω

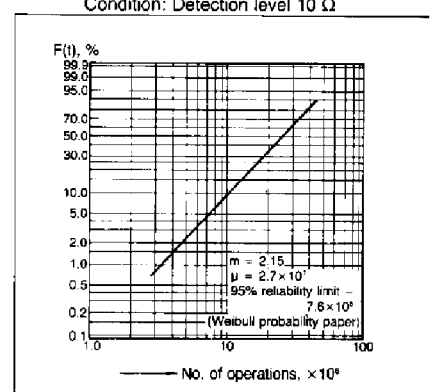

14.-(2) Contact reliability
(100 μ A 5 V DC resistive load)
Tested sample: TQ2-12V
Condition: Detection level 100 Ω

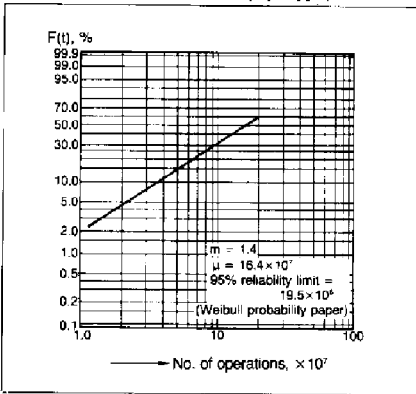

15. Pulse dialing test (35 mA 48 V DC wire spring relay load)

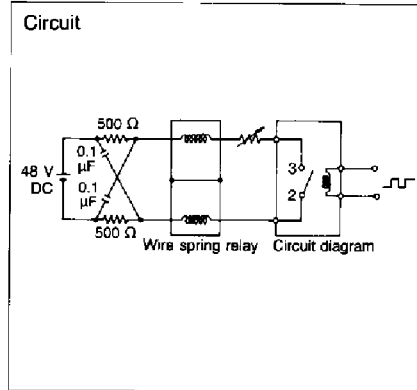

Change of pick-up and drop-out voltage

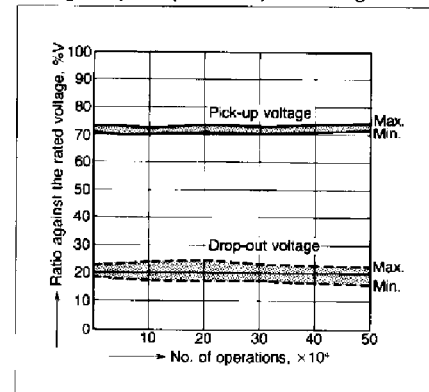

Change of contact resistance

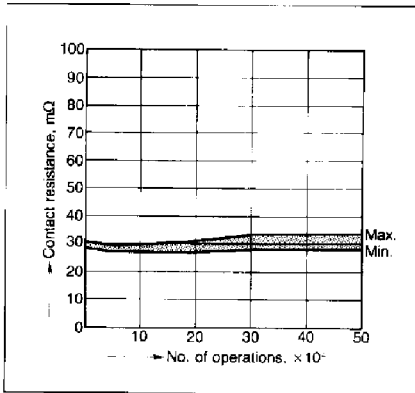

16. 0.1 A 53 V DC resistive load test
Change of pick-up and drop-out voltage

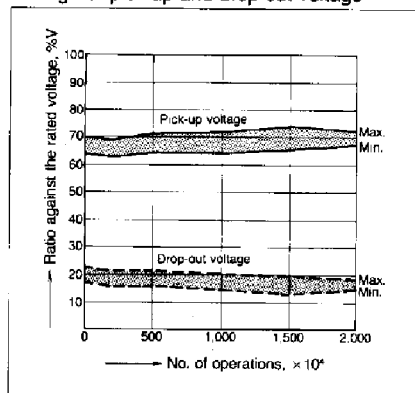

Change of contact resistance

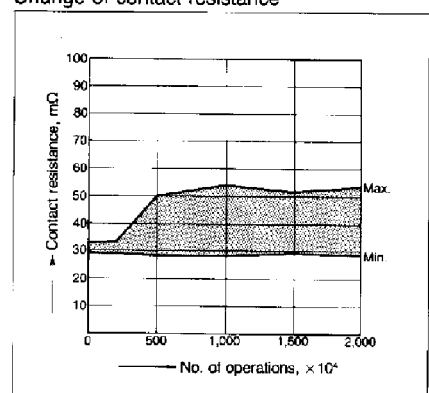

NOTES

1. Coil operating power

Pure DC current should be applied to the coil. The wave form should be rectangular. If it includes ripple, the ripple factor should be less than 5%. However, check it with the actual circuit since the characteristics may be slightly different.

2. Coil connection

When connecting coils, refer to the wiring diagram to prevent mis-operation or mal-function.

3. External magnetic field

Since TQ-relay is highly sensitive polarized relay, its characteristics will be affected by a strong external magnetic field. Avoid using relays under that condition.

4. Cleaning

In automatic cleaning, cleaning with the boiling method is recommended. Avoid ultrasonic cleaning for relays. It is recommended that a fluorinated hydrocarbon or other alcoholic solvents be used. Trichlene and chloroethene can be used for cleaning.

5. Packing direction

Relays are packed in a tube with the orientation stripe (PIN No. 1) toward the gray stopper.

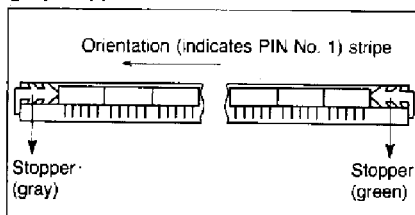

6. Automatic insertion

To maintain the internal function of the relay, the chucking pressure should not exceed the values below.

Chucking pressure in the direction A:

500 g or less*

Chucking pressure in the direction B:

1 kg or less

Mounting pressure in the direction C:

1 kg or less

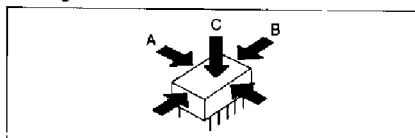

*Avoid chucking the center of the relay.

7. Soldering

Preheat according to the following conditions.

Temperature	100°C 212°F or less
Time	Within 1 minute

Soldering should be done at 250°C 482°F within 5 sec.

8. Others

1) If in error the relay has been dropped, the appearance and characteristics should be checked before use without fail.

2) Latching relays are shipped from the factory in the reset state. A shock to the relay during shipping or installation may cause it to change to the set state. Therefore, it is recommended the relay be used in a circuit which initializes the relay to the required state (set or reset) whenever the power is turned on.